

**NEW**

Employing a wire-type fuse-element, the DC500VBC2035 has realized a rated current of 180 A while still maintaining the conventional  $\phi 20 \times 33$  mm dimensions.

**DC500VBC2035**

RoHS \*1

**DC500V**



Scale: 1/2

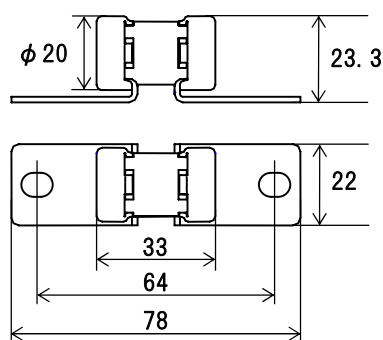

Unit: mm

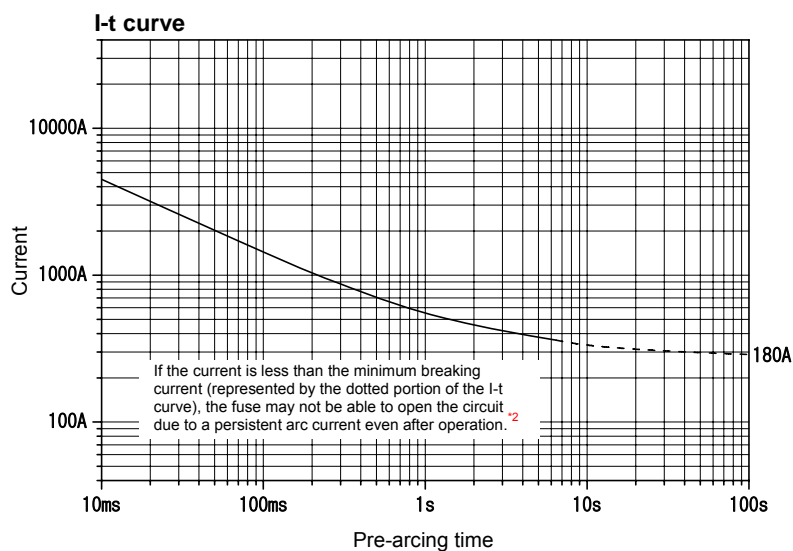

The I-t curve above is based on the average values of measurements obtained under testing conditions specified by our company. The information is for reference purposes only, and is not intended to infer any guarantees of performance.

Rated voltage	Certification	Rated current ( $I_N$ )	Rated breaking current		Minimum breaking current *2	Temp. rise $0.5I_N$	Overload operation $5.0I_N$
DC500V	—	180A	2000A	Resistive circuit	360A	50K or less	Within 1s

\*1: High melting temperature type solder containing more than 85 wt% lead is used in this product.

\*2: "Minimum breaking current" is the minimum current value that this fuse can safely interrupt to open a resistive circuit of DC 500 V in which this fuse has been inserted. When fusing occurs at currents of less than the minimum breaking current, continuous arcing may occur, or a previously extinguished arc may reoccur, and it may therefore not be possible to break the current. Do not apply fusing conditions of currents less than the minimum breaking current to the fuse, as fires and other accidents may occur due to the inability to open the circuit.