

Representative pre-arcing time-current characteristics

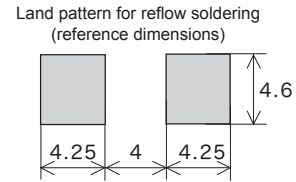
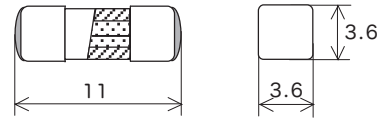
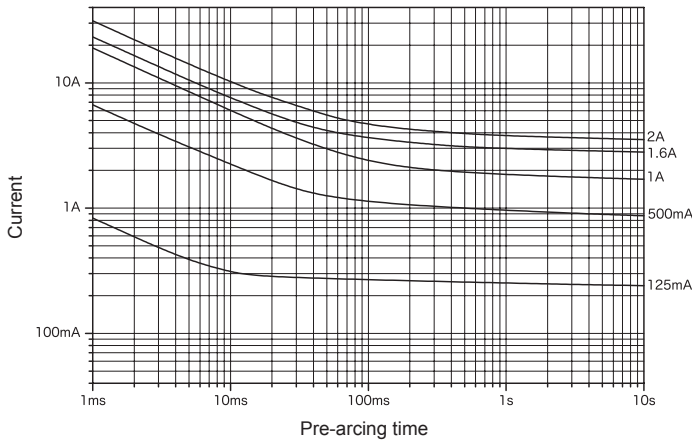

Scale: 2/1 (mm)

Rated voltage	Certification	Rated current (I_N)	Rated breaking current		Temp. rise	Current carrying capacity	Overload operation
DC 600 V		63 mA–3.15 A *1	100 A	Resistive circuit	75 K or less at 1.0 I_N	1.0 I_N until temperature stabilization occurs	Within 60 s at 2.0 I_N
DC 425 V		4 A					

*1: Customer-requested rated current values can be supplied from within the given range.

*2: This product uses high melting temperature type solder containing 85% by weight or more lead. This type of solder is exempted from the RoHS Directive.

SMC N4

Pre-arcing time-current characteristics

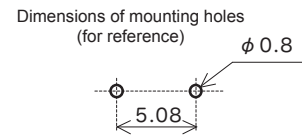
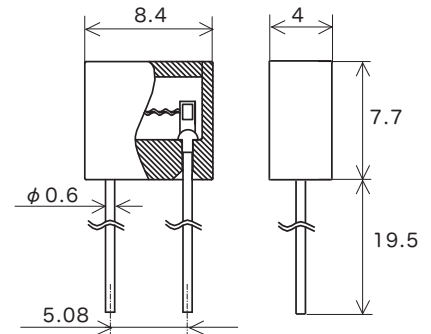
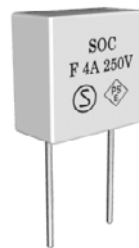
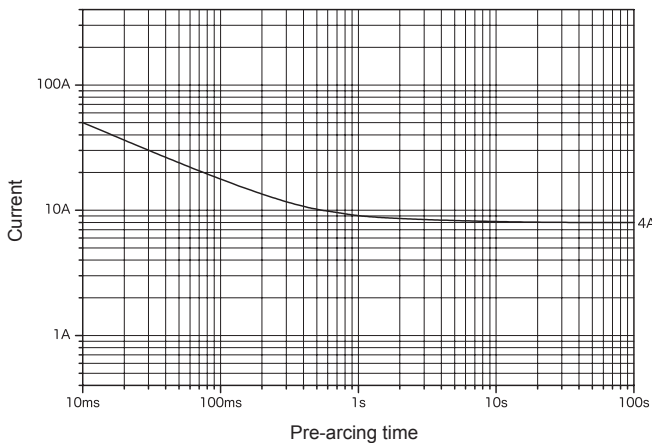

Scale: 2/1 (mm)

Rated voltage	Certification	Rated current (I_N)	Rated breaking current		Temp. rise	Endurance test / Current carrying capacity	Pre-arcing time-current characteristics
AC 250 V		4 A	40 A	PF over 0.95	*1	*2	*3
			50 A		75 K or less at 1.0 I_N	1.0 I_N until temperature stabilization occurs	Within 30 min at 2.1 I_N

*1: After passing 1.5 I_N through 15 min, the current is increased by 0.1 I_N every 15 min until the fuse operates. While the current is being increased, the temperature rise at each part of the fuse shall not exceed 135 K.

*2: After repeating 100 cycles of the rated current 1 h on / 15 min off, 1.5 I_N is passed through the fuse for 1 h.

*3:

2.1 I_N	2.75 I_N	4.0 I_N	10 I_N
Within 30 min	0.01 s–3 s	0.003 s–0.3 s	Within 0.02 s